

# **The Terminated Coaxial Cage Monopole (TC2M)**

## **A new design of Broadband HF vertical antenna**

**© Martin Ehrenfried – G8JNJ**

Please note that this information is provided free to individuals who wish to construct their own version of this antenna for personal use.

Companies or individuals, who wish to produce commercial versions for re-sale, should contact the author and inventor to discuss terms and conditions associated with the reproduction of the design.

It is requested that potential purchasers of component parts, or whole antenna systems, should only use approved suppliers. This is in order to ensure that they are supplied with good quality products that work correctly. All approved suppliers will be listed the <http://www.tc2m.info> website

This article was first published in RadCom © May-June 2014 RSGB, [www.RSGB.org](http://www.RSGB.org) and is reproduced with their kind permission. Copies should not be made for commercial purposes without prior approval.

This information can be referenced from other websites and on-line forums but acknowledgement should be made to the original source.

TC2M - Design and information © Martin Ehrenfried - G8JNJ - 2014

# A new design of broadband HF vertical antenna

## Part 1: background and development concepts

**INTRODUCTION.** For several years I have been exploring and testing the design of various HF broadband antennas, many of which are documented on my website [1]. This article outlines the background and the development of a new type of efficient, omnidirectional broadband vertical antenna that requires no tuner. The design is protected by patent [2], but I have no objection to individuals building one for personal use. The second part of this article will contain detailed construction details.

**BACKGROUND.** With the evolution of high frequency (HF) radio systems and the increasing use of digital communication techniques, there is a requirement for antennas to be capable of instantaneous operation over a wide range of operating frequencies. Examples include commercial, military and amateur stations undertaking frequency hopping, propagation monitoring, beaconing, WSPR or similar activities.

**DESIGN GOALS.** Modern transmitters are designed to have a nominal output impedance of  $50\Omega$ : to achieve this specification, many antennas incorporate matching networks. Such networks are often only efficient across a relatively narrow range of operating frequencies, typically  $\pm 10\%$ . In transmission systems where rapid changes in operating frequencies are required, some form of active tuning system is necessary in order to maintain the correct matching

impedance and efficient transfer of radio frequency (RF) energy. Active tuning networks are undesirable as they require a finite settling time before any transmission can commence. Rapid switching of such networks is usually implemented by electromechanical devices, which only have a limited number of operating cycles before they need to be replaced.

A few types of antennas have a relatively constant  $50\Omega$  feed impedance over a wide frequency range. This group of antennas includes bicone, disccone and log periodic arrays, which are the most common broadband designs used for transmission purposes at VHF and higher frequencies. It is possible to use them on lower frequency bands, but the physical dimensions that are required for such antennas make them unpopular for anything other than fixed, or point to point communications.

Compact broadband antennas use various techniques to achieve a  $50\Omega$  feed impedance across a very wide frequency range. This often relies upon introducing some form of resistive loss that is large enough to dominate excessive impedance excursions. However, any loss results in reduced efficiency, as less power is available to be radiated from the antenna.

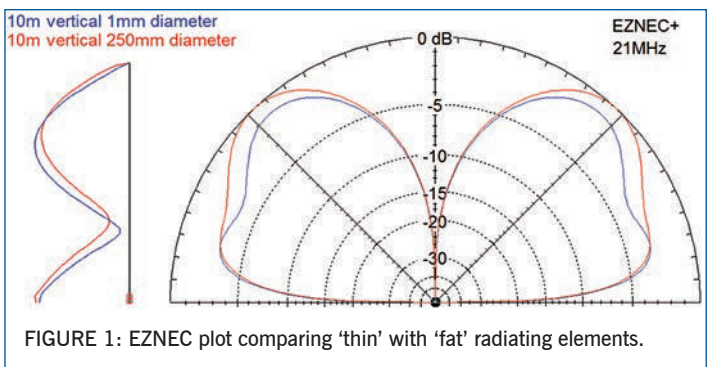

FIGURE 1: EZNEC plot comparing 'thin' with 'fat' radiating elements.

In this article I wish to demonstrate that by using a combination of the best of these techniques it is possible to design a new type of antenna that is capable of efficient, predictable operation over a very wide frequency range.

In order to simplify

explanations from this point onwards. I will only consider a monopole antenna fed against a suitable ground plane. Although it should be noted that the information and descriptions are equally applicable to dipole antennas, by considering them as two monopoles connected back to back, with no requirement for a ground plane, the impedance values are doubled.

### EXISTING BROADBAND ANTENNAS.

The easiest way to increase the operating bandwidth of a simple monopole or dipole antenna is to use a 'fat' radiating element, or to emulate one by bundling multiple conductors in order to make the overall diameter a substantial proportion of its total length. The length to diameter ratio plays a significant factor in maximising the operating bandwidth of such antennas at the fundamental  $\frac{1}{4}$  wave resonance of each radiating element.

With 'thin' antennas there is an additional problem that occurs when the electrical length of an antenna begins to exceed  $\frac{3}{8}$  of a wavelength. The radiation pattern starts to split and deep nulls form in between the main radiation lobes. However, as we progressively increase the diameter of the radiating element so that it becomes fatter, a number of interesting changes occur.

With a fat conductor the current and phase distribution along the radiating element becomes modified and starts to depart from a standing wave pattern to be more like that of a travelling wave. This has a significant effect on the radiation pattern as nulls start to become 'filled' and minor lobes disappear.

Lobe filling is particularly noticeable at frequencies where the antenna is

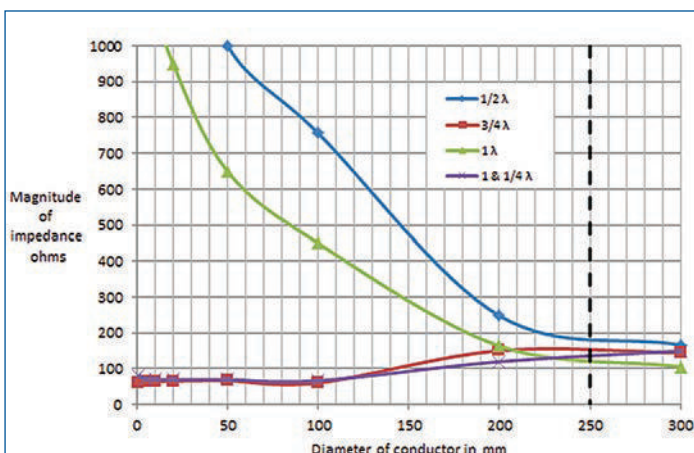
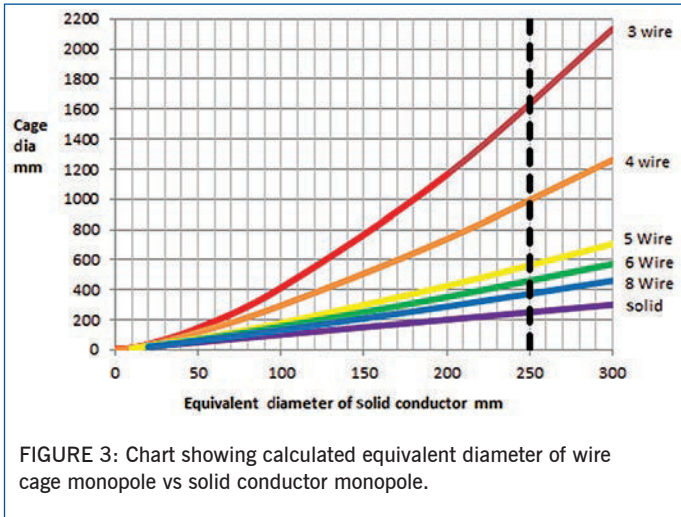

FIGURE 2: Monopole formed from solid conductor calculated magnitude of feed impedance vs diameter of conductor.



$\frac{3}{2}$  or 2 wavelengths long and is a very useful quality in vertically polarised communication antennas. It can improve the performance at intermediate 'skip' zone distances and, in some cases, increases the useful gain. Figure 1, which was produced from an EZNEC [3] model, shows this in more detail. The left hand side of the diagram shows a graphical representation of the current distribution along a 10m tall vertical radiator, whilst the right hand side shows the resulting radiation pattern.

Small diameter radiating elements, such as those constructed from thin wire, have a large range of impedance excursions at the feed point. This can vary from a few tens of ohms, at odd multiples of the fundamental  $\frac{1}{4}$  wave resonance, up to several thousand ohms at even multiples. As the diameter is increased the high feed impedance at  $\frac{1}{2}, \frac{2}{2}, \frac{3}{2}, \frac{4}{2}$  wavelength etc starts to fall; whilst the low feed impedance at  $\frac{3}{4}, \frac{5}{4}, \frac{7}{4}$  wavelength etc begins to rise slightly. Note that both the resistive and reactive the range of impedance excursions are diminished, which reduces the SWR when used without a tuner and decreases the reactance range that needs to be matched when a tuner is used.

Figure 2 shows the EZNEC-modelled feed impedance of a typical 10m long HF vertical antenna, using a solid conductor of gradually increasing diameter.

Note that once a conductor diameter of approximately 250mm (or 10") has been reached, the feed impedance at  $\frac{1}{2}, \frac{3}{4}, 1$  and  $\frac{5}{4}$  wavelengths begins to converge at a value of around 150 to 170Ω. This corresponds to a length to diameter ratio of 40.

Further increases in conductor diameter will continue to modify the feed impedance, but in terms of the size of a practical antenna, this tends to produce diminishing returns, especially when the diameter of the antenna becomes a sizable proportion of its overall height. If the diameter is increased to a sufficiently large value, the

feed impedance will become close to 50Ω. This technique is used in the conical monopole antenna and variants. However the desire to obtain a 50Ω feed impedance comes at a price. As an example, a 10m high antenna would require a maximum diameter of about 8m. This is quite a bit larger than the 250mm diameter solid conductor previously mentioned.

In many cases it is impracticable to construct a vertical radiating structure with a minimum conductor diameter of 250mm. However it is possible to simulate a solid conductor by making a 'skeleton' circular wire cage of a suitable number of much smaller diameter conductors connected in parallel.

It is possible to calculate [4] the size of cage and number of wires that would be required to simulate a conductor of a given size and plot them graphically. In this case we are interested in cages constructed from 1mm diameter wire that represent a solid conductor with a minimum diameter of 250mm as shown in Figure 3.

It is possible to confirm that the practical results closely match these calculated values by measuring the actual feed impedance of a selection of different diameter 10m tall vertical monopoles, as shown in Figure 4.

The vertical scale shows the amplitude of the measured feed impedance, and the horizontal scale shows the frequency. Note that I have limited the maximum value of impedance shown on the graph, in order to make some of the lower impedance traces more legible.

When using a very thin wire radiating element, the impedance swings quite dramatically between a maximum value

supporting vertical antennas, constructed from moderately large diameter tube, are so popular for multiband operation.

However, when using a skeleton cage, if the spacing between the wires of the cage starts to become a substantial proportion of a wavelength, the equivalence to a single large diameter conductor becomes flawed. This can be seen around the 100MHz end of the frequency range, where the 0.4m diameter 5 wire cage has a lower feed point impedance in comparison to the much wider 1m diameter 5 wire cage.

This leads to the conclusion that a 10m high, 5 wire cage monopole fed against an adequate ground plane would be suitable for operation on the HF bands. Providing that a cage diameter of greater than 0.6m is used, the average feed impedance across a very wide range of frequencies lies somewhere in the region of 150 to 170Ω. This is a very easy impedance to match to a value near 50Ω, by means of a 4:1 ratio broadband impedance transformer or unun, producing a worst case SWR of no greater than 3:1 on any frequency from approximately 7MHz to well over 70MHz. This ensures that the unun is always operating close to its designed matching range, reduces coax mismatch losses and is suitable for use with most built-in antenna tuners.

I was able to verify this form of antenna, by making RF field strength measurements from transmissions using different vertical antennas, all having the same length of radiating element, but with varying diameters or numbers of wires forming a cage.

In order to make these measurements I used a remote controlled spectrum analyser and broadband active antenna. This was mounted on the roof of a building at approximately 20m AGL that was approximately 8km away from the transmitter site, well outside the near field zone of the transmitting antenna. I found that providing that the measurements were conducted under similar conditions; the repeatability was normally within  $\pm 0.5$ dB, which I could verify by making a reference

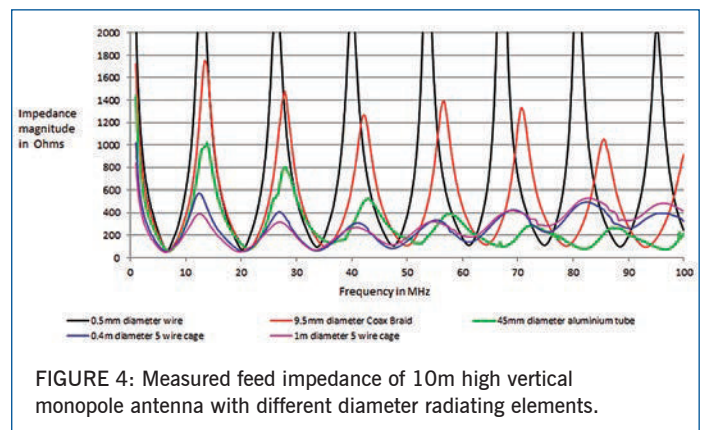



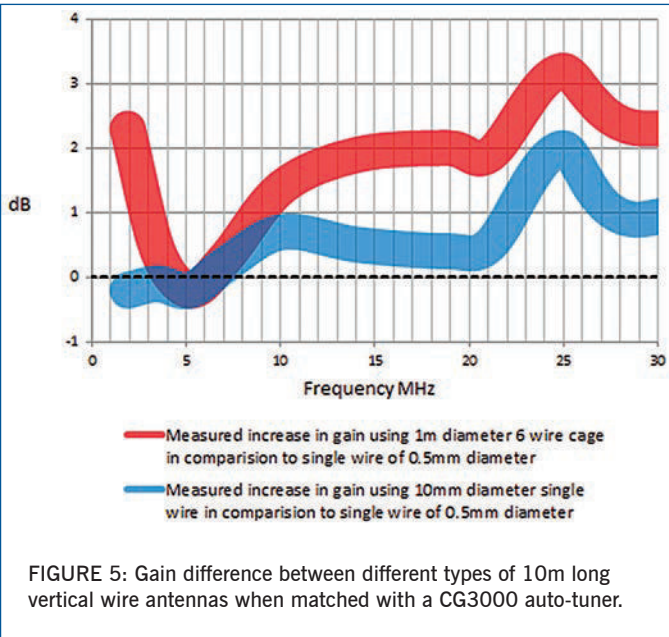

**RESISTIVELY TERMINATED ANTENNAS.** Another group of broadband antennas use a different technique to achieve a 50Ω impedance match across a very wide frequency range. This relies upon either using a resistive load to mask excessive impedance excursions, or treating the radiating element as a form of terminated transmission line. It should be noted that in the majority of cases, adding a resistive termination

desired matching range. Adding inductive, capacitive, or resistive networks at various points along the radiating element(s) is another method used in some military antenna systems. It is also possible to use some other component such as an impedance matching transformer that is specifically designed to incorporate resistive loss. There are many examples of this technique being used in commercial antennas being sold on the amateur market such as the Comet CHA250 (and copies). Alternatively, distributed resistive loss can be introduced along the radiating elements as proposed by Wu & King [5], or by other similar methods [6].

The more efficient types of resistively terminated antennas tend to be those based on various forms of transmission lines. These are known as travelling wave antennas and include designs such as the Beverage and rhombic antenna.

Un-terminated antennas have a standing wave current (and voltage) distribution along their length. When a wave propagates along the antenna from the source to the end of the radiating element, it encounters an open circuit and is reflected back toward the source. This interacts with other waves travelling from the source and adds and subtracts with the incident wave. This forms peaks and troughs in the current (and voltage) distribution along the radiating element. If the feed point is at a current maximum, the feed impedance will be low, and conversely if the feed point is at a current minimum, the feed impedance will be high.

If the peaks and troughs occur at  $\frac{1}{4}$  wavelength intervals of the applied frequency, they form standing waves. If we move our feed point along the radiating structure the impedance will vary, depending upon its position relative to that of the standing wave pattern. This principle is used in the off-centre fed dipole, where the point feed is chosen to be in approximately the same position (or impedance value) relative to the standing wave pattern on multiple harmonically related amateur bands.

measurement at the start and finish of each session. **Figure 5** shows the results averaged over many test runs.

Note that reference field strength was produced by using a thin (0.5mm diameter) vertical wire. This was matched to 50Ω at the base of the antenna by means of a CG3000 auto-tuner. This particular model of auto-tuner incorporates air spaced coils and has matching losses that are typical of many common makes of tuner.

The results clearly show that a measured improvement in field strength of up to 3dB (twice the power) could be achieved simply by using a larger diameter of radiating element.

Increasing the wire diameter from 0.5mm to 10mm slightly improves the efficiency, but using a six wire cage makes a dramatic improvement. This was much greater than predicted by *EZNEC* [3]. In fact, I was so amazed by these results that I took great care to verify them by using several different types of tuners and of matching networks. All the tuners produced very similar curves resulting in a big difference in comparative performance between the thin wire and cage at around 25MHz. I believe that this could be because the impedance presented by the thin wire was more difficult to match than the moderate impedance presented by the wire cage antenna and this may have significantly reduced tuner losses at these frequencies.

One other factor, which was mentioned previously, is that the RF current distribution in a cage antenna results in the presence of a much greater amount of travelling wave current; this may have also helped to improve the antenna gain at low angles of radiation in comparison to the single thin wire radiating element.

also reduces antenna efficiency, so a compromise has to be struck between overall size, bandwidth and gain.

Resistive loss may be introduced in the form of a resistor, in conjunction with some sort of radiating element. Probably the simplest example of this type of antenna is a 50Ω resistive load connected directly across the transmitter output, and a length of wire acting as the radiator. I have tried this and it does work. But the efficiency is very low, somewhere in the region of about 20dB worse than a similar length of wire fed via a suitable matching unit.

Other commercial antennas, such as the Diamond BB7V vertical and BB6W wire antenna, use combinations of impedance matching transformers and load resistors to achieve broadband operation. The efficiency of these designs may be several dB worse than a similar length of wire fed from a suitable matching unit, but have the advantage of providing a load impedance that is manageable by most transceivers incorporating a built in antenna tuning unit. This permits the full transmitter output power to be used, without an SWR protection circuit operating and reducing the output to a safe level.

By distributing resistive losses around various parts of the antenna structure, it may be possible to only introduce resistive impedance damping on specific frequencies, where the feed impedance would otherwise be outside the

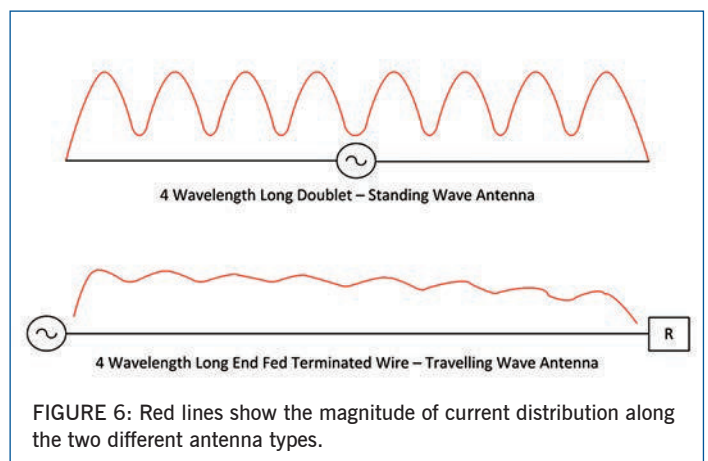

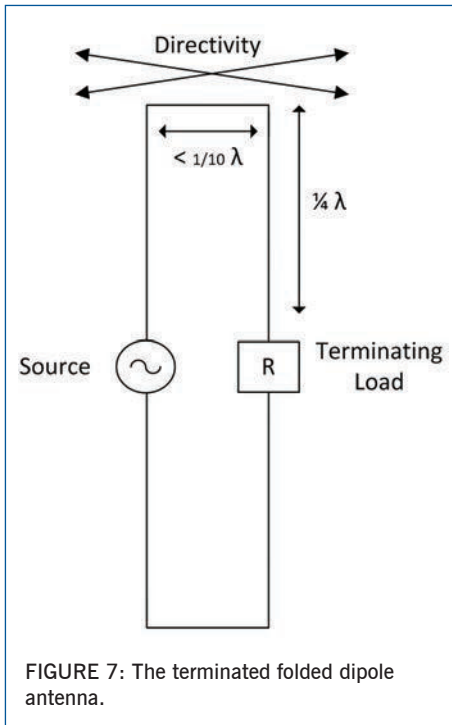

It is possible to modify the standing wave pattern of an electrically long antenna by terminating the far end with a suitable value of resistive load. The remaining (non-radiated) part of the forward wave is then absorbed and not reflected back towards the source, so the current distribution along the radiating element is relatively constant. This is referred to as a travelling wave antenna.

However, a practical radiating element does not form a perfect balanced transmission line, so the fields associated with the antenna are not confined to the immediate vicinity of the radiating element. This means that it is not possible to provide a perfect non-reflecting termination. Consequently there will still be some slight peaks and troughs in the current distribution along the radiating element. These excursions are fairly small, so the feed impedance remains relatively constant no matter where the source is placed along the radiating element, providing the length of radiating element is several wavelengths long. The antenna is no longer frequency conscious, and can be used over a very wide operating bandwidth. Figure 6 shows the difference in current distribution.

The terminated folded dipole is one example of a relatively compact broadband antenna. However, because the antenna is electrically small (less than a few quarter waves long) on most operating frequencies, it does not operate as a true travelling wave antenna, but it does have some similarities. Not all the reflected power is absorbed in the terminating load but a reasonable proportion is, particularly at lower frequencies, which reduces the overall antenna efficiency.

However, this absorption also has the desirable effect of reducing the amplitude of any standing waves which may form along the radiating element, improving the match at the feed point. This basic principle is used in commercial antennas such as the terminated folded dipole [7] shown in Figure 7.

Note that this design requires a relatively large spacing between the parallel elements in order to radiate efficiently. Very closely spaced conductors, such as those used in commercially manufactured twin feeder or coaxial cable, have a coupling factor that is designed to minimise unwanted radiation when used as a transmission line. The equal and opposite currents flowing in each conductor (differential current flow) will suppress RF energy in the form of common mode current from being radiated. Because the resistive load is placed at the opposite side of the antenna to the feed point the resulting phase relationship of the total current distribution from the antenna in one direction is additive, and in the other direction subtractive. So the radiation pattern is slightly asymmetric, with about 2dB less gain in some directions on certain frequencies.

In order to improve upon some of these shortcomings, a variant of the original terminated folded dipole uses two outer wires either side of a central wire. The central wire is being used to connect to the terminating load. This forms a more symmetrical antenna (only in two planes), with improved radiation efficiency, less asymmetry and much more constant feed impedance.

**TERMINATED FOLDED MONOPOLE.** It is possible to modify the terminated folded dipole, by just using half of the antenna and feeding it against the ground. This results in a Terminated Folded Monopole. A practical version of such an antenna was first published in *AntenneX* magazine [8]. In this design, half a terminated folded dipole is orientated vertically and fed against a ground screen that is used to provide the 'missing' other half of the antenna. However, the design does not include any specific details with respect to the optimum conductor spacing. It also suffers from the lower gain and pattern asymmetry associated with the terminated folded dipole antenna it is originally derived from. Figure 8 shows the general form of this antenna.

**ANTENNA LOADING.** Another method of extending the low frequency performance of an antenna is to add an additional length of conductor to the radiating element in order to make it appear to be electrically longer than it actually is. The additional conductor can be arranged to run alongside or parallel to the radiating element, or in

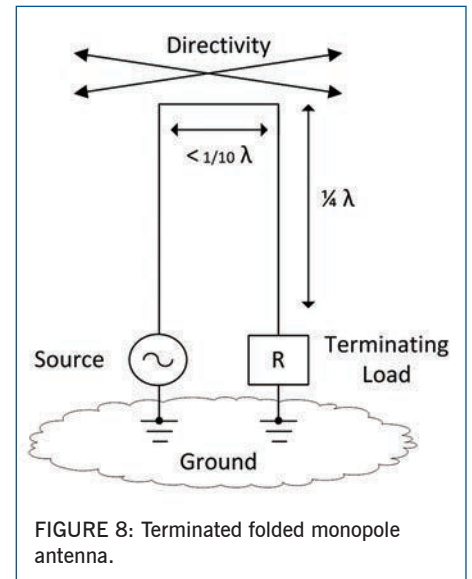

some cases, coiled around it. If we were to remove the resistive terminating load from the terminated folded monopole antenna shown in the previous drawing and leave the connection open circuit, we would then have a linearly loaded  $1/4$  wave antenna as the loading wire is  $1/4$  wavelength long. The total electrical length of the antenna would now be a  $1/2$  wave at the original frequency.

For example a 7MHz vertical  $1/4$  wave antenna, when linearly loaded in this way, would appear to be electrically similar to a  $1/4$  wave antenna operating on 3.5MHz. Although the impedance measured at the feed point would be very similar, the actual performance and radiation efficiency would not be the same. This is due to a combination of factors, including losses in the folded radiating structure, which could be considered as length of mismatched but closely coupled twin transmission line. In this case the partial cancellation of currents travelling along the parallel conductors would reduce the overall antenna radiation efficiency.

In the next part I will describe how many of the features of these existing designs can be incorporated into a new type of antenna that is compact, efficient, cost effective and easy to construct.

**WEBSEARCH**

- [1] G8JNJ website: [www.g8jnj.webs.com](http://www.g8jnj.webs.com)
- [2] GB2485812
- [3] EZNEC: [www.eznec.com/](http://www.eznec.com/)
- [4] Reg Edwards, G4FGQ, Cage dipole calculator, <http://home.centurytel.net/badgerlake/Hamradio/calcs/dipcage1.exe>
- [5] *The Cylindrical Antenna with Non-Reflecting Resistive Loading*, T T Wu & R W P King
- [6] US patents US5644321, 691985 & 3950757
- [7] Terminated folded dipole patented by Barker & Williams on 27 December 1983, US patent 4423423
- [8] A wide-band folded vertical, Dave Cuthbert, WX7G, June 2002 *AntenneX* magazine No 62

# A new design of broadband HF vertical antenna

This second and final part describes the practical design

PHOTO 1: Prototype Terminated Coaxial Cage Monopole, with wires emphasised for better visibility.



**TERMINATED COAXIAL CAGE MONOPOLE (TC2M).** The previous part of this article outlined several ways of producing broadband or electrically loaded antennas. In this section I'll show how these differing techniques can be brought together, to produce an innovative new design that provides a distinct advantage over many of the previous types.

Please note that this design is protected by patent [9]. I have no objection to individuals building copies for their own use. However commercial manufacturers who wish to reproduce the design should contact me to discuss licensing. All approved manufacturers are listed on the TC2M website [10].

As a starting point, the symmetry of the Terminated Folded Dipole / Monopole antenna can be improved by adding additional feed wires around the terminated load wire. Although adding a resistive load can reduce the overall efficiency of an antenna, if a skeleton cage of wires is placed around a central load wire, radiation from the load wire is suppressed, the pattern asymmetry decreases, and the antenna efficiency increases with respect to that of a standard terminated design.

By transforming the antenna into a wire cage the natural bandwidth of the antenna is widened and excessive impedance excursions at the feed point are tamed. This was demonstrated in the first part of this article, where it was suggested that a five wire cage seemed to offer the best compromise between overall size, bandwidth and ease of construction. Adding an extra central 'load' wire makes the antenna appear to be electrically longer than it actually is. This helps to further improve the impedance match, towards the lower end of the operational frequency range.

The outer wire cage, in conjunction with the central 'load' wire, forms a 'skeleton' coaxial transmission line. The impedance of the transmission line can be adjusted by varying the conductor diameter and spacing. This can be used to optimise the match between the radiating 'cage' section of the antenna and a terminating load. Placing the terminating load at the end of the central loading wire, rather than connecting it directly across the secondary of the unbalanced to unbalanced transformer (unun) results in much less power being dissipated in the load and a better match throughout the operational frequency range of the antenna.



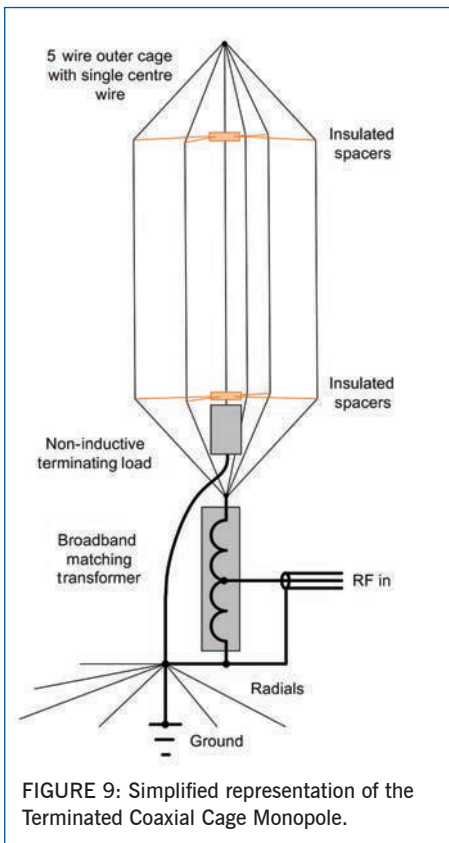

FIGURE 9: Simplified representation of the Terminated Coaxial Cage Monopole.

So by combining the best aspects of 'fat' cage antenna and a Terminated Folded antenna, it is possible to achieve a very wide instantaneous bandwidth and good efficiency, without the need for a tuneable antenna matching unit.

A simplified representation of the new design is shown in **Figure 9** and **Photo 1**.

**IMPLEMENTATION.** The choice of cage dimensions needs to be made by trading various parameters against each other in order to optimise the performance. This nearly always involves having to make some compromises, which will depend upon the required frequency coverage, method of construction and placement of the antenna.

There are many factors affecting this design, including:

**Length & height of cage** – by making a suitable choice of the overall length it is possible to maximise efficiency over the required operating bandwidth. The upper HF frequency limited by beam tilt when the antenna is greater than  $5/8$  wavelength long. The lower LF frequency is determined by the acceptable level of efficiency required by the user. A 10m long cage is capable of providing good performance over the frequency range 1.8 to 70MHz. A longer cage would be more efficient on the lower frequency bands, but performance on the higher frequency bands is likely to be degraded as a result.

**Diameter of cage** – this affects the bandwidth & range of feed impedance. Increasing the diameter of the cage increases the bandwidth and lowers the peak value of

feed impedance. Adding more wires allows the diameter of the cage to be reduced but increases the complexity of construction and weight of the antenna. Consideration also needs to be given to the ease of constructing a coaxial cage transmission line of the required characteristic impedance. The characteristic impedance is set by the choice of wire gauge and cage diameter. Increasing the distance between cage and terminated centre wire can minimise mismatch loss.

**Number of wires** – the more wires that are added the more the radiating element looks like a single conductor. If the spacing between the wires becomes excessive (greater than  $1/4$  wave) large impedance variations will occur at higher frequencies. The *absolute* minimum number of cage wires should be three.

**Height above ground plane** – this determines the feed impedance and radiation efficiency at the HF and LF ends of operating frequency range. Ideally, a reduced size ground plane should be more conductive near the feed point, as the maximum amount of current flows in this region.

**Impedance of terminating load** – this determines the overall flatness of SWR curve across whole frequency range, especially the maximum SWR at the low frequency end of the operational bandwidth (less than  $1/4$  wave), but also the efficiency at LF due to the amount of power absorbed by the terminating load.

**Practical design** – for this implementation I have chosen to use a five wire cage with one centre wire to form the coaxial cage antenna. I believe this offers the best compromise in terms of overall radiation efficiency, ease of construction and cost of materials. As mentioned earlier, fewer than five wires results in much less consistent performance at the upper end of the frequency range, as the spacing between adjacent wires starts to become a significant proportion of a wavelength long. Using more than five wires provides very little additional improvement.

The exact method of implementing the Terminated Coaxial Cage Monopole can be modified to accommodate different construction techniques or specific design requirements. I have built versions using self-supporting telescopic GRP tube, guyed

fishing poles and have also suspended wire cages from the limbs of trees. It may also be possible to use a rigid tube or tower to form the outer cylinder of the design. Providing a suitable diameter centre wire can be found, to form a transmission line section of the correct characteristic impedance. The low 'Q' broadband nature of the design means that it is not particularly susceptible to interaction with nearby objects. This makes it ideal for use in urban environments.

The overall length of the antenna can be modified to optimise the performance over a broad frequency range. If an overall length of 10m is chosen, it is possible to achieve a usable operating bandwidth of 1.5MHz to 70MHz, along with good overall radiation efficiency throughout most of the frequency range.

All six wires are connected together at the top of the antenna structure and the five outer wires are fed against a ground plane by means of a suitable unun at the base of the antenna. The central wire is connected to the ground plane at the base of the antenna structure, via a series connected terminating load.

**MECHANICAL CONSTRUCTION.** In this example the basic construction consists of a central vertical conductor surrounded by five wires forming the radiating cage. The wires are spaced by means of a central 'hub' with five 'spokes', all of which are made from a suitable dielectric, non-conductive insulating material such as plastic or GRP. When constructing the prototypes I used plastic furniture castors to make the hubs. I found that it was useful to hold them in a wooden jig, which makes them very quick and easy to drill out using a standard pillar (press) drill. **Photo 2** shows a simple jig used as a drilling guide.

The spokes were made by cutting up a cheap set of 5mm diameter GRP cable access rods and fitting sleeved grommets on the ends to help secure the wires and to prevent injuries to passers-by. By shopping around it is possible to build several sets of insulated spacers for under £10.

The spacers are arranged to form a suitable support structure for the wire frame coaxial transmission line. By using 1mm diameter insulated wire with centre wire to outer wire spacing of 0.4 to 0.5m. A wire cage coaxial transmission line, with a characteristic impedance of approximately 400 to 450Ω is formed. It is possible to use thicker diameter wire, but the wire to wire spacing has to be increased in order to maintain something close to the target value of characteristic impedance. If you choose to use larger spacing between wires, you may also need to increase the number of wires forming the outer screen of the antenna. This is because the effectiveness of the wire screen decreases, as the spacing between the outer wires becomes greater than  $1/10$

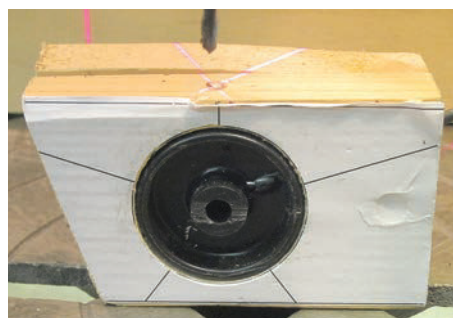

PHOTO 2: A simple jig used when making the insulators from castors.

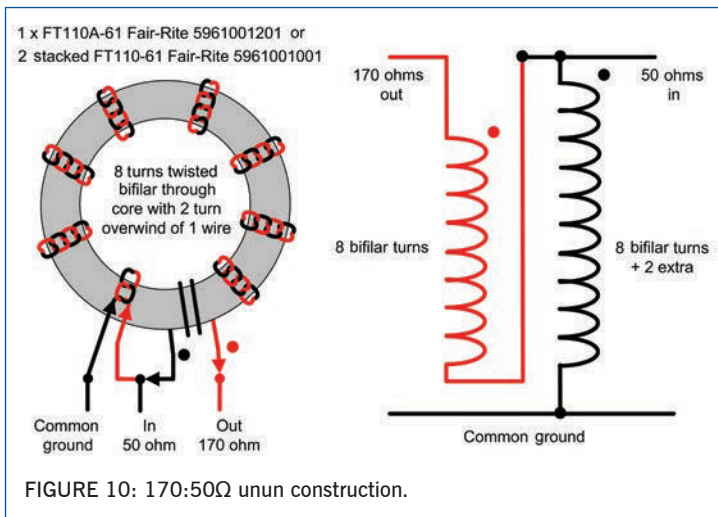

FIGURE 10: 170:50Ω unun construction.

of a wavelength at the highest operating frequency.

**CONSTRUCTION OF UNUN.** The input impedance at the feed point of the antenna is in the region of 150 to 170Ω. It is possible to use a standard design of 4:1 ratio Ruthroff (voltage) unun to achieve a reasonable match. However, in order to get the best results, it is preferable to use a non-standard ratio; although many constructors may consider that it is not worth the additional effort, it really doesn't take any more time to build.

I recommend the design shown in **Figure 10**, which I have tested for extended periods with CW power levels of up to 250W. I used silver plated PTFE covered wire, but any reasonable diameter cable with good insulation would be acceptable. The choice of core size and material is critical. Do not substitute other types of ferrite or iron powder cores. If built correctly this design is easily repeatable, with a reasonably

consistent impedance transformation and minimum amount of through loss, as shown in **Figures 11** and **12**.

**CONSTRUCTION OF TERMINATING LOAD.**

One of the biggest challenges during this project was to source a high resistance, high power, non-inductive terminating load. Most non-inductive resistors are not suitable for this purpose as they only exhibit a non-inductive characteristic at frequencies below 1MHz.

The power dissipation of the resistive load needs to be chosen to match the required transmitter power. For CW operation a wattage rating of 50% of the transmitter power should be used. If other forms of modulation such as SSB are used that have a lower duty factor, then the wattage rating of the terminating load can be reduced accordingly.

Also note that if there is inadequate heat sinking, or airflow, the overall power rating

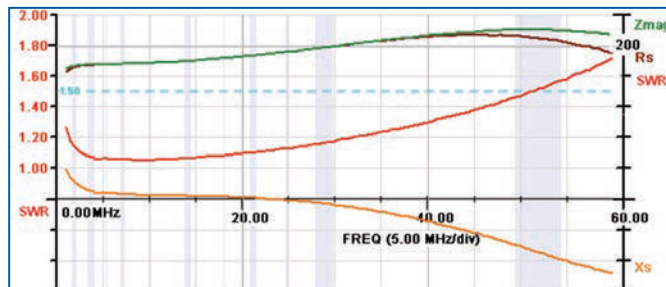

FIGURE 11: Unun impedance transformation.

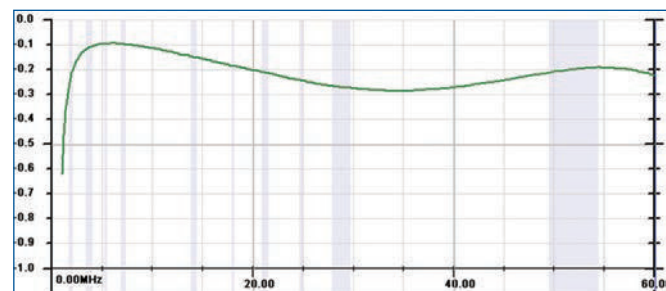

FIGURE 12: Unun through loss in dB.

of any resistor may need to be reduced; especially if it is installed in a sealed enclosure, or mounted too close to other resistors in the bundle.

It is possible to modify the feed impedance versus frequency characteristics of the antenna by changing the value of load resistance. Computer modelling using *EZNEC* [11] suggested that a resistance value of 450 to 470Ω, which is approximately three times the feed point impedance, would provide the best match across the required range of operating frequencies.

I was fortunate when I built the first prototype, as I found that some cheap unmarked 10W ceramic cased wire wound resistors that I bought online exhibited a predominantly resistive impedance curve at frequencies up to about 30MHz. This is particularly desirable at the low frequency end of the operating frequency range, where the antenna is less than 1/4 of a wavelength long. I was able to construct a 470Ω terminating load, by connecting ten 4K7 resistors in parallel. This was capable of dissipating 100W. However a later batch of resistors bought from the same supplier were not suitable. So if you decide to use this method of construction, some experimentation with different makes and quantities of resistors may be required to get the best results. I would really only consider this option if you have access to suitable impedance measuring equipment.

One other technique I tried was to replace the fixed value of terminating load with a suitable ratio broadband impedance transformer and high power 50Ω load. One method would be to use a 9:1 (450:50Ω) transformer with a standard 50Ω terminating load. In fact I used this technique to measure the amount of power being dissipated in the load at various operating frequencies during

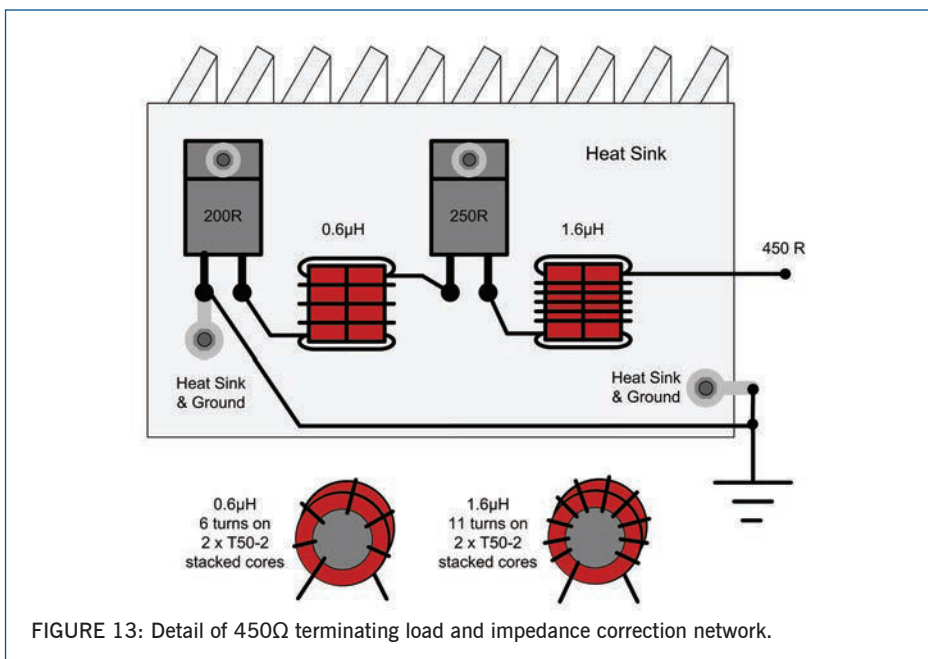

FIGURE 13: Detail of 450Ω terminating load and impedance correction network.



tests of my prototype designs. However it is very difficult to build a 9:1 unun with a flat impedance transformation ratio over the required frequency range so I abandoned this idea and resumed my quest to obtain repeatable results from standard parts.

I used a network analyser to measure a variety of different resistors, including types specifically designed for use as RF loads. Unfortunately most of these are only available in standard values of 50 or 100Ω. So I tried connecting several in series to obtain something near the desired value of 470Ω. But the distributed capacitive reactance was excessive, mainly due to the resistors having to be flange mounted onto a heat sink. This was true of most, non-inductive thick film resistors that I tried, but I eventually determined that two 30W rated Caddock TO-220 thick film resistors connected in series were most suited in this application. The number of the parts I used were MP930-200-1% 200Ω ohm 30W 1% and MP930-250-1% 50Ω 30W 1%.

However even these resistors still have a significant amount of capacitive reactance present when mounted on a heat sink. So in order to provide a more satisfactory value of resistive impedance across the required frequency range, I found it necessary to include two inductors in order to compensate for the distributed capacitive reactance present in the series connected resistors. The final configuration is shown in **Figure 13**. The improvement in match can be clearly seen in **Figure 14**.

The full layout of the input transformer and terminating load, which is capable of being used with transmitter powers of up to 100W, is shown in **Photo 3**. Note that by building the whole unit in one box, which is also used to provide a heatsink for the load resistors, it is possible to quickly configure the antenna as either a conventional unun fed cage monopole, or as a TC2M. This can be achieved by simply disconnecting the centre wire from the black terminal and re-connecting it, along with the five outer cage wires, to the red terminal. This feature is useful if you are concerned about the amount of power being dissipated in the terminating load, as it makes it very easy to

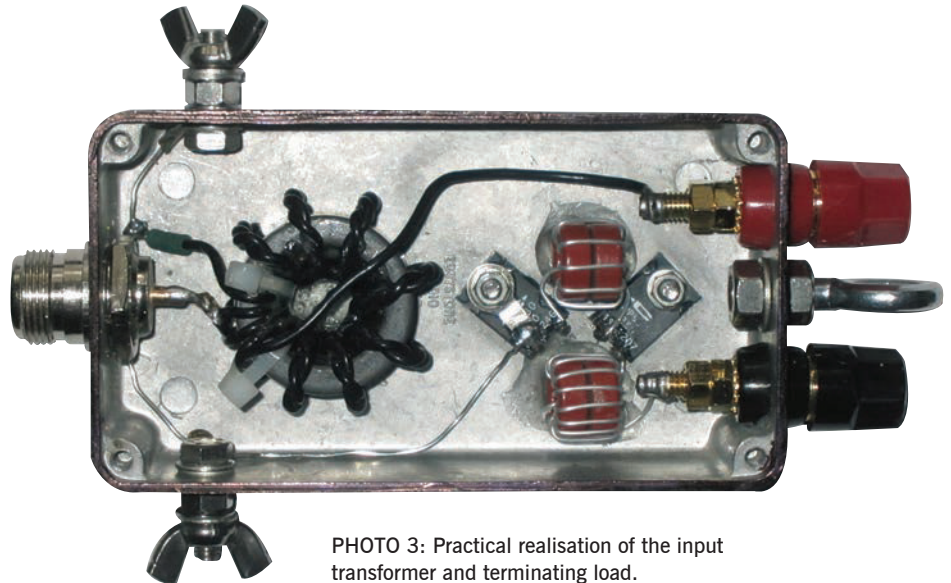

PHOTO 3: Practical realisation of the input transformer and terminating load.

compare the performance in the two different configurations.

**GROUND SCREEN.** In order to operate in an efficient manner, this antenna (as is the case with all vertical monopole antennas) needs to be fed against an appropriately dimensioned ground screen (ground plane, radials or counterpoise wires). Ideally this would take the form of a continuously conductive metal sheet, extending out to beyond 1/4 of a wavelength at the lowest required operating frequency. However in most cases this would not be practical to implement.

The next best solution would be a series of wire spokes extending out away from the base of the antenna out to beyond 1/4 wavelength at the lowest required operating frequency. A minimum of 8 buried wires would seem to offer the best compromise between cost, effort and efficiency.

If this is not possible then as many radial wires as possible should be used. If the wires are considerably shorter than 1/4 of a wavelength at the lowest required operating frequency, then it is better to use more wires. In practice, eight wires of 10m length with a further eight wires of 5m length laid in-between each other on the surface of the soil will produce reasonable results on most frequencies.

Although the antenna is designed for broadband operation, it may be that unwanted resonances are present in the radial wires. This is especially true if they are laid on the surface of the soil, in which case then, combinations of different lengths may be required in order to achieve a smooth impedance match across the required frequency range. Ideally, radial wires should be

buried at a depth of at least 25mm in order to reduce the incidence of self-resonance.

**PERFORMANCE.** **Figure 15** shows the input impedance over the operating frequency range of 1 to 60MHz. This has been measured directly at the antenna feed point, with no additional cable losses. Note that the SWR does not exceed 2.5:1 and in most cases is less than 2:1. This means that the antenna can be used without the need for a tuner over the entire frequency range.

In a practical installation, a moderate length of coaxial cable will be required to connect the antenna to the transceiver. In such cases the SWR measured at the transceiver will appear to be even lower, due to the additional cable losses.

**EFFICIENCY.** The main limit on efficiency with the TC2M antenna is the amount of power dissipated in the terminating load and power wasted due to mismatch loss between the unun transformer and the antenna structure. Many engineers will naturally express concern about deliberately adding resistive loss into an antenna system. However, unwanted losses occur in all practical antennas. This can be through resistive or dielectric losses in cables, conductors, ground systems, matching networks and tuners. Although most designers would endeavour to reduce such losses, they can easily be in the region of 0.5 to 2dB, depending upon the impedance range presented to the tuner. In this design the unun is nearly always operating into impedance that is close to its design value, so losses are greatly minimised.

On frequencies where the antenna is shorter than an electrical 1/4 wavelength, the resistive feed impedance of the radiating element decreases, and the mismatch losses associated with the unun transformer become much greater. Other losses also increase due to a greater proportion of the applied power

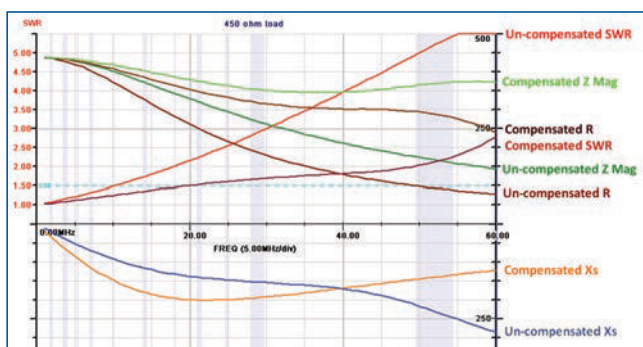

FIGURE 14: Terminating load characteristics with and without impedance compensation.

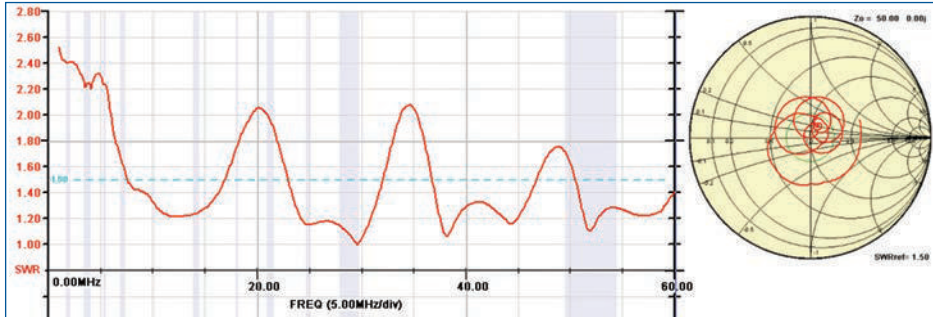

FIGURE 15: Input impedance from 1 to 60MHz, measured at the feedpoint.

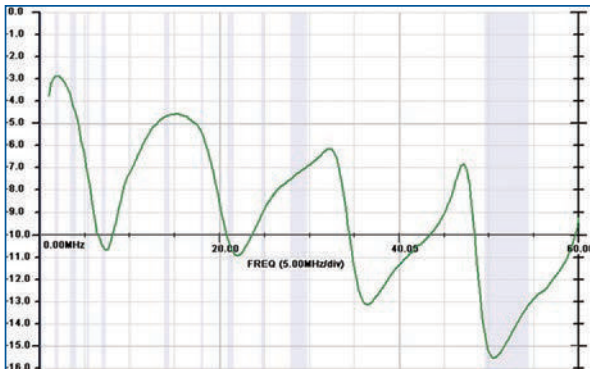

FIGURE 16: Power measured in terminating load relative to applied input power.

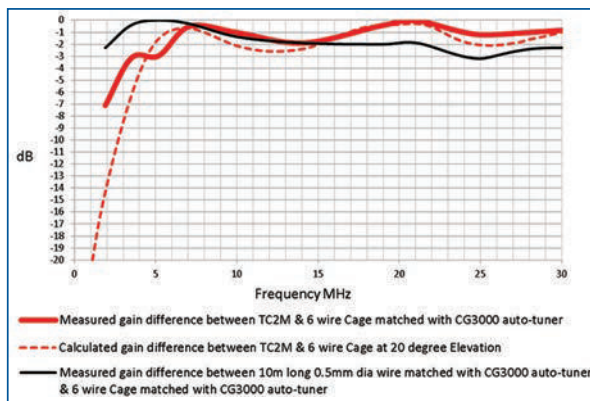

FIGURE 17: Gain difference between cage and wire antenna with tuner and TC2M.

being absorbed by the terminating load and ground resistance. It is possible to quantify the amount of power being absorbed by the terminating load simply by replacing it with a 9:1 unun terminated with a 50Ω power meter or network analyser.

This graph in **Figure 16** shows the actual measured RF power being dissipated in the terminating load relative to the applied RF input power. This is expressed as a ratio in dB relative to input power at various operating frequencies.

In order to get the losses associated with the terminating load into perspective, especially at the low frequency end of the operating range, the power dissipated in the load should be compared with the considerable amount of power that is lost due to ground resistance when the resistive component of the feed impedance is in the order of only a few ohms. Although

it is difficult to accurately measure the gain of an antenna directly, the performance can be modelled and compared against a reference antenna of similar size. It is then possible to validate the predicted results by measuring the radiated field strengths of both types of antenna.

I have been able to verify these results, by making measurements with a remotely operated spectrum analyser and active antenna. **Figure 12** shows the results of these measurements that were produced by transmitting a test signal and connecting the vertical antenna in different configurations.

When connected as a ‘fat’ radiator, with the terminating load removed and all six wires connected in parallel, at both the top and the bottom of the wire structure, a 50Ω match to the transmitter and coaxial cable could easily be achieved by means of a good quality automatic antenna tuner connected directly to the unun at the base of the antenna. The

antenna was fed against 10 mixed length buried radial wires. These extended in a circular pattern away from the base of the antenna. The advantage of using the same basic cage antenna as the reference was that it made it very quick and easy to remove the ATU and reconnect the terminating load to configure the antenna as a TC2M without disturbing the rest of the setup and cabling that could, otherwise, affect the accuracy of any measurements.

The graph in **Figure 17** shows the calculated and measured gain differences between antennas. It clearly demonstrates a very good correlation at frequencies higher than 7MHz. Where the monopole is greater than 1/4 of a wavelength long, the Terminated Coaxial Cage Monopole is almost as efficient as the cage antenna with auto-tuner.

I have also included another plot in **Figure**

17 for reference purposes. This shows the performance of a similar length of thin wire and an auto-tuner in comparison to the cage antenna and tuner. This is the same configuration that I outlined in part one of this article. Note that on some frequencies at the higher end of the operating range the TC2M is actually 1 or 2dB more efficient than using a similar sized length of thin wire and auto-tuner.

At frequencies below 1/4 wave electrical length the efficiency of the Terminated Coaxial Cage Monopole gradually tails off in a predictable manner, but it is still capable of providing useful operation at frequencies as low as 1.8MHz. In fact, tests on 160m have demonstrated a similar level of performance to that of a 100ft G5RV sized doublet (not connected as a Tee).

Note that the measured performance at the lower end of the frequency range is actually better than the modelled values. This is not an error. The most likely explanation is that the system losses of the cage antenna, tuner and ground resistance are worse than calculated. So by comparison the TC2M results seem better than would perhaps be expected. This is not untypical of electrically short antennas on the LF band, as ground and tuner losses can be significant due to the low resistive and high capacitive value of feed impedance encountered with such designs. These are quite often not noticed by operators unless measurements can be taken, or comparisons made with other antennas. Although I have mainly focused on measuring the transmission efficiency, it should also be noted that the design functions very well as a wideband receive antenna. The reduction in gain at lower frequencies is not an issue, as the received signal to noise ratio tends to remain fairly constant, being dominated by external factors such as the location of the antenna relative to external noise sources, rather than its absolute gain.

**CONCLUSION.** I hope that you have found this article informative and that it may have stimulated you to construct your own version of the TC2M antenna. I have found it to be very easy to build, as it is suited to the use of a variety of different construction techniques and materials. It can be made to be visually unobtrusive and not unduly influenced by nearby objects. It is therefore ideal for use in difficult or urban environments, where other designs may prove to be problematic. The simplicity of the design makes it easy to maintain. Whilst its performance is equal to, or better than, many commercial designs that cost considerable amounts of money. Try it and see!

**WEBSEARCH**

- [9] GB2485812
- [10] www.tc2m.info
- [11] www.eznec.com/